

## Fasteners Assembly Instructions for D22

**Applying for products:**

1139 D22-PC-NH / 1139 D22-EXP-NH

1139 D22-PC-SH / 1139 D22-EXP-SH

1139 D22-PC-3H / 1139 D22-EXP-3H

Part number	Description	Qty/per set
AC01	Hex Head Bolt M12 x 40mmL x P1.25	6
AC02	Nyloc Nut M12 x P1.25	12
AC03	Steel Nord Lock Washer M12 x 13mmID x 19mmOD x 2.2mmT	6
AC04	Steel Flat Washer M12 x 13mmID x 26mmOD x 2.2mmT	36
AC05	M6 x 10mmL x P1 Steel Hex socket (allen Key) & Domed Head Bolt	12
AC06	M6 x 12mmL x P1 Steel Hex socket (allen Key) & Domed Head Bolt	8
AC07	Steel Spring Washer M6	8
AC08	Steel Flat Washer M6 x 6.6mmID x 15mmOD x 2mmT	8
AC09	M4 x 15mmL x P0.7 Hex socket (allen Key) & Domed Head Bolt	12
AC10	Steel Flat Washer M4 x 4.3mmID x 9mmOD x 0.8mmT	16
AC11	Nyloc Nut M4 x P0.7	4
AC12	Hex Head Bolt M8 x 25mmL x P1.25	4
AC13	Nyloc Nut M8 x P1.25	10
AC14	Steel Flat Washer M8 x 8.4mmID x 17mmOD x 2.5mmT	19
AC15	Steel Spring Washer M8	5
AC16	Hex Head Bolt M16 x 30mmL x P2	4
AC17	Steel Flat Washer M16 x 17mmID x 30mmOD x 2.5mmT	4
AC18	Hex Head Bolt M8 x 20mmL x P1.25	5
AC19	Steel Bolt M12 x 115 x P1.25	6
AC20	Steel Bolt M10 x 30 x P1.25	4
AC21	Steel Flat Washer M10 x 11mmID x 21mmOD x 2mmT	8
AC22	Steel Nyloc Nut M10 x P1.25	4
AC30	Electric Cable Packed	1
AC31	Frog Lights (Pair) with Accessories	1
AC32	Indicator Lights (Pair)	1

GENERAL VIEW

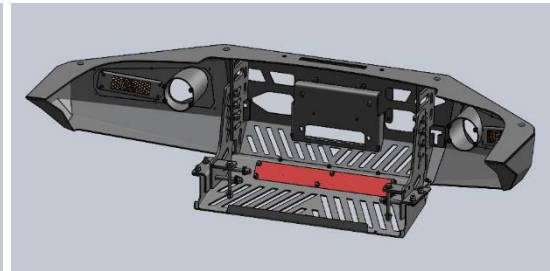
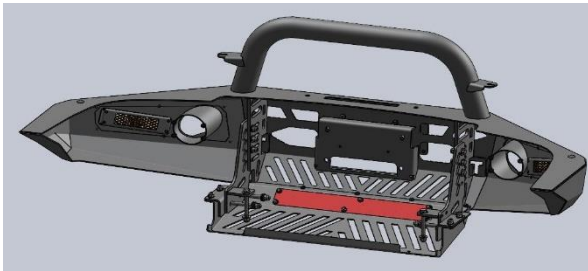
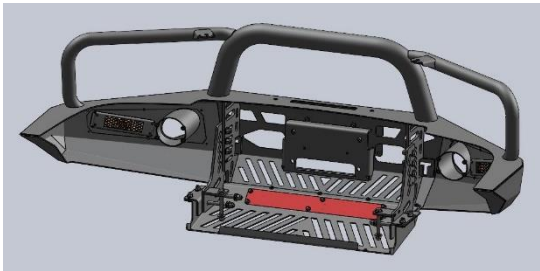
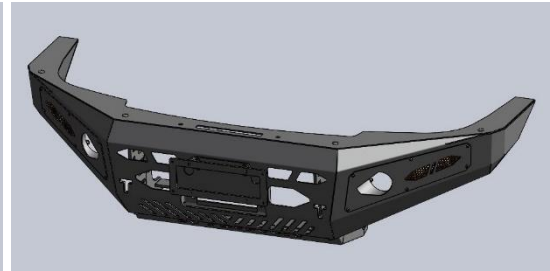

3 HOOP

SINGLE HOOP

NO HOOP

WI-008-R0

**STEP 1:** Install Brackets into the Car, bolted both sides with 6 positions.

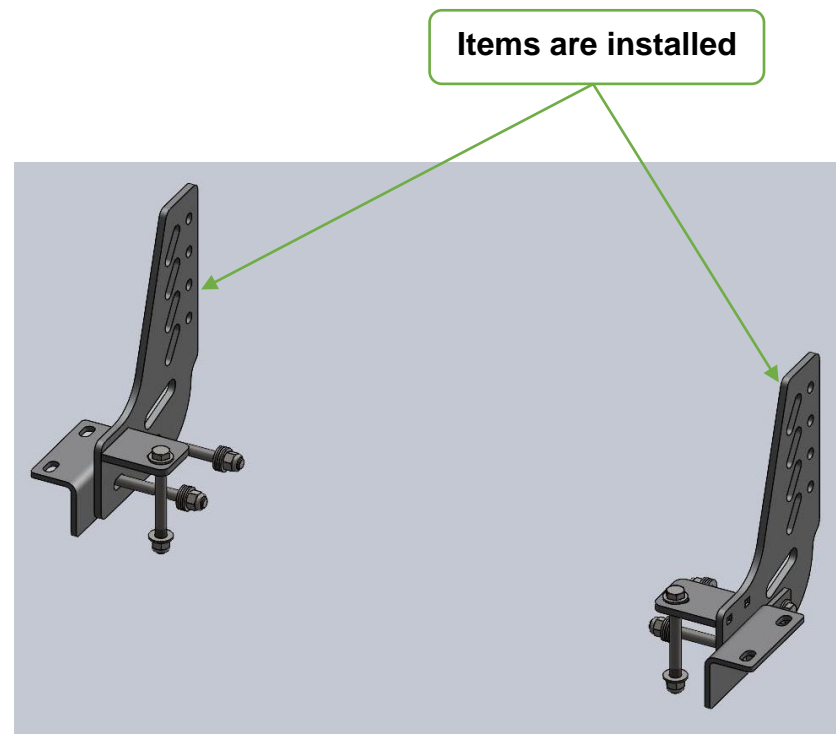
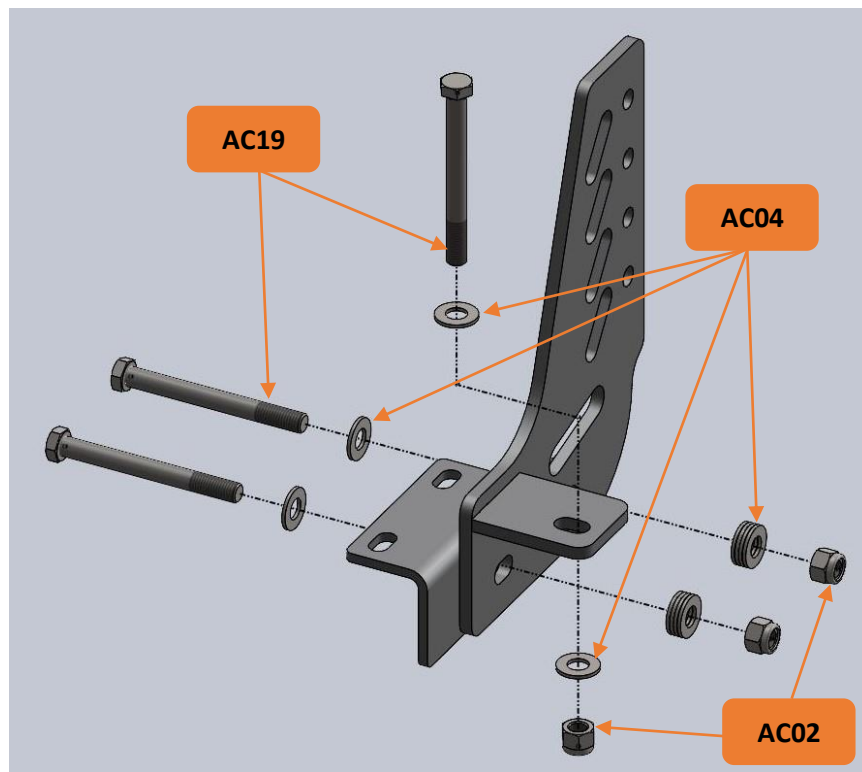

**AC02 x 06 pcs** : Nyloc Nut M12 x P1.25

**AC04 x 24 pcs** : Steel Flat Washer M12 x 13mmID x 26mmOD x 2.2mmT

**AC19 x 06 pcs** : Steel Bolt M12 x 115 x P1.25

**Bolt Tightening Torque: 88(Nm)**

WI-008-R0

**STEP 2:** Install Bull Bar Body into the Car, bolted both sides with 6 positions.

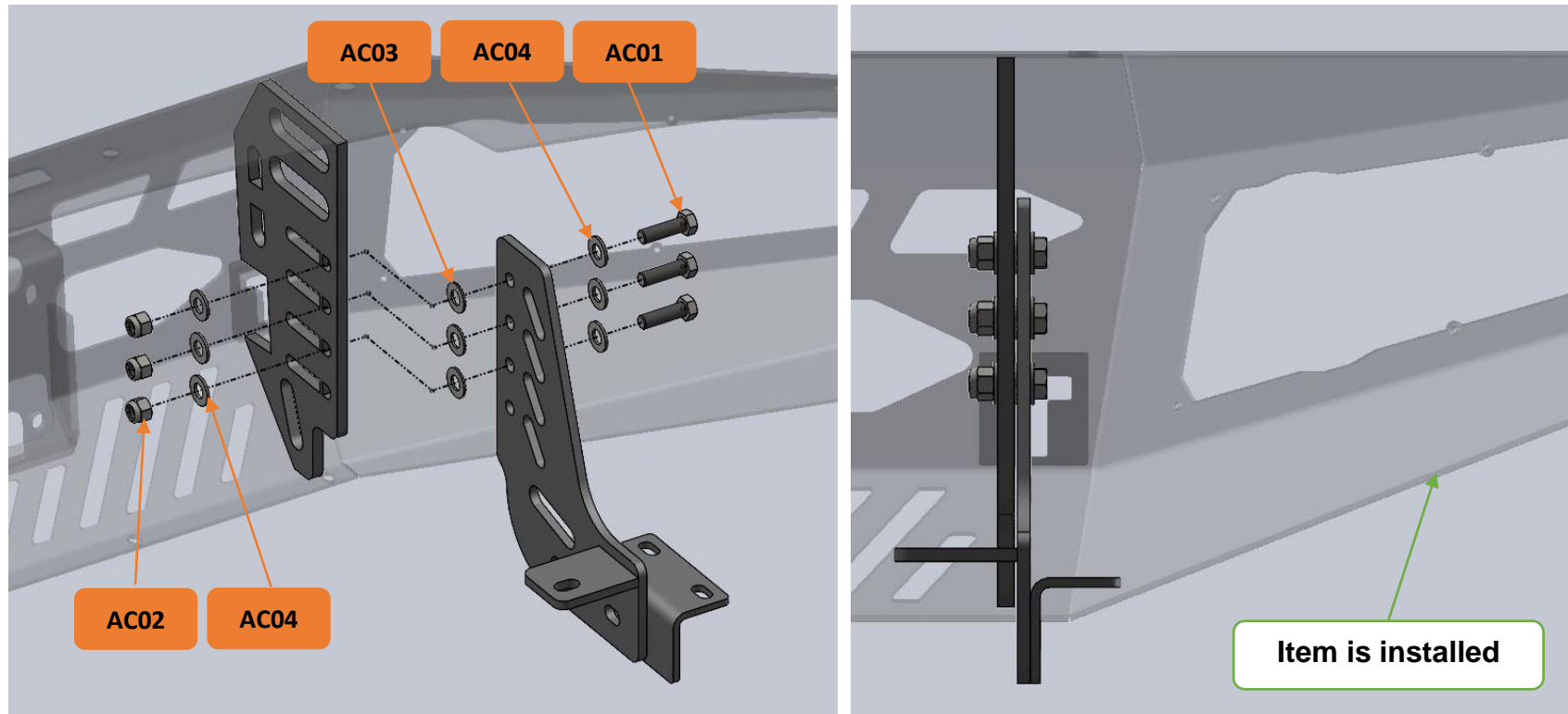

**AC01 x 06 pcs** : Hex Head Bolt M12 x 40mmL x P1.25

**AC02 x 06 pcs** : Nyloc Nut M12 x P1.25

**AC03 x 06 pcs** : Steel Nord Lock Washer M12 x 13mmID x 19mmOD x 2.2mmT

**AC04 x 12 pcs** : Steel Flat Washer M12 x 13mmID x 26mmOD x 2.2mmT

**Bolt Tightening Torque: 88(Nm)**

WI-008-R0

**STEP 3.1:** Install 3 Hoop into the Car, bolted with 4 positions. **[Use for 3 Hoop only]**

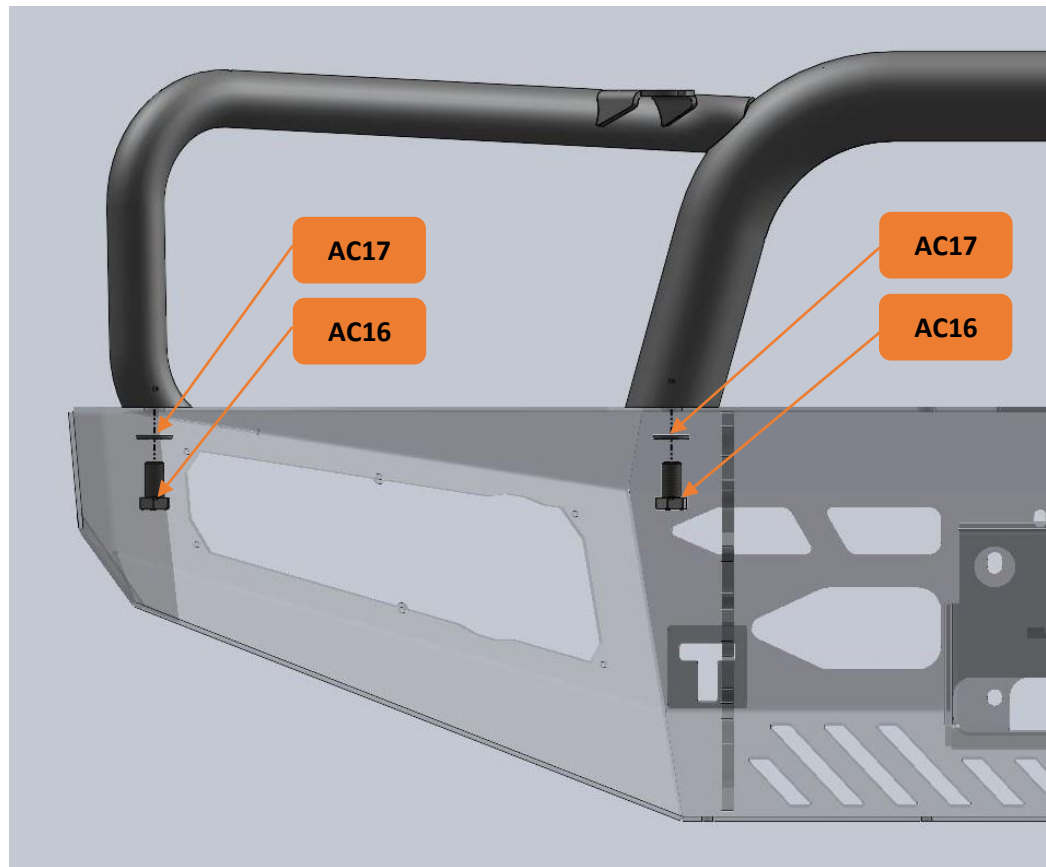

**AC16 x 04 pcs** : Hex Head Bolt M16 x 30mmL x P2

**AC17 x 04 pcs** : Steel Flat Washer M16 x 17mmID x 30mmOD x 2.5mmT

**Bolt Tightening Torque: 88(Nm)**

WI-008-R0

**STEP 3.2:** Install Single Hoop & Plastic Cap into the Car, bolted with 4 positions. **[Use for Single Hoop only]**

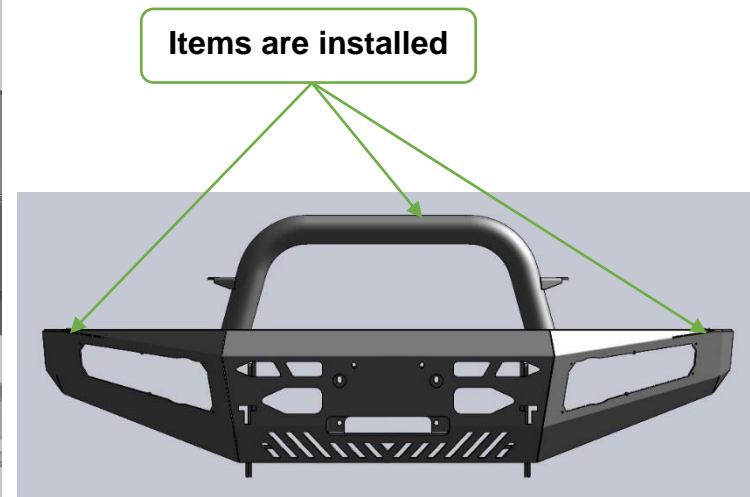
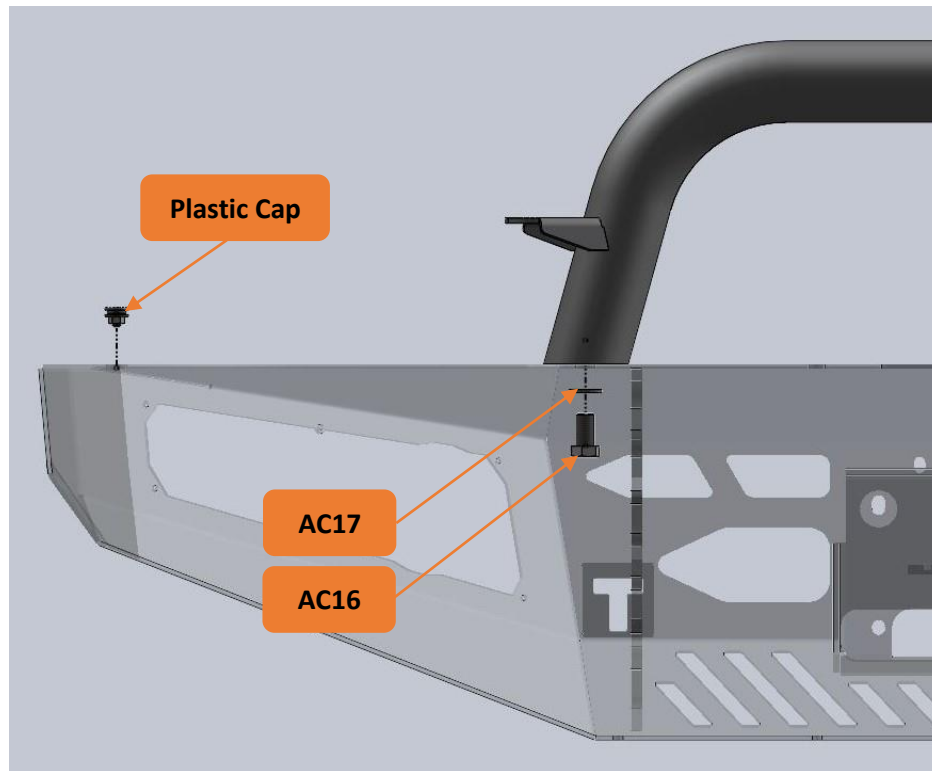

**Plastic Cap x 02 pcs**

**Bolt Tightening Torque: 3(Nm)**

**AC16 x 02 pcs :** Hex Head Bolt M16 x 30mmL x P2

**AC17 x 02 pcs :** Steel Flat Washer M16 x 17mmID x 30mmOD x 2.5mmT

**Bolt Tightening Torque: 88(Nm)**

WI-008-R0

**STEP 3.3:** Install Plastic Cap into the Car, bolted with 4 positions. **[Use for No Hoop only]**

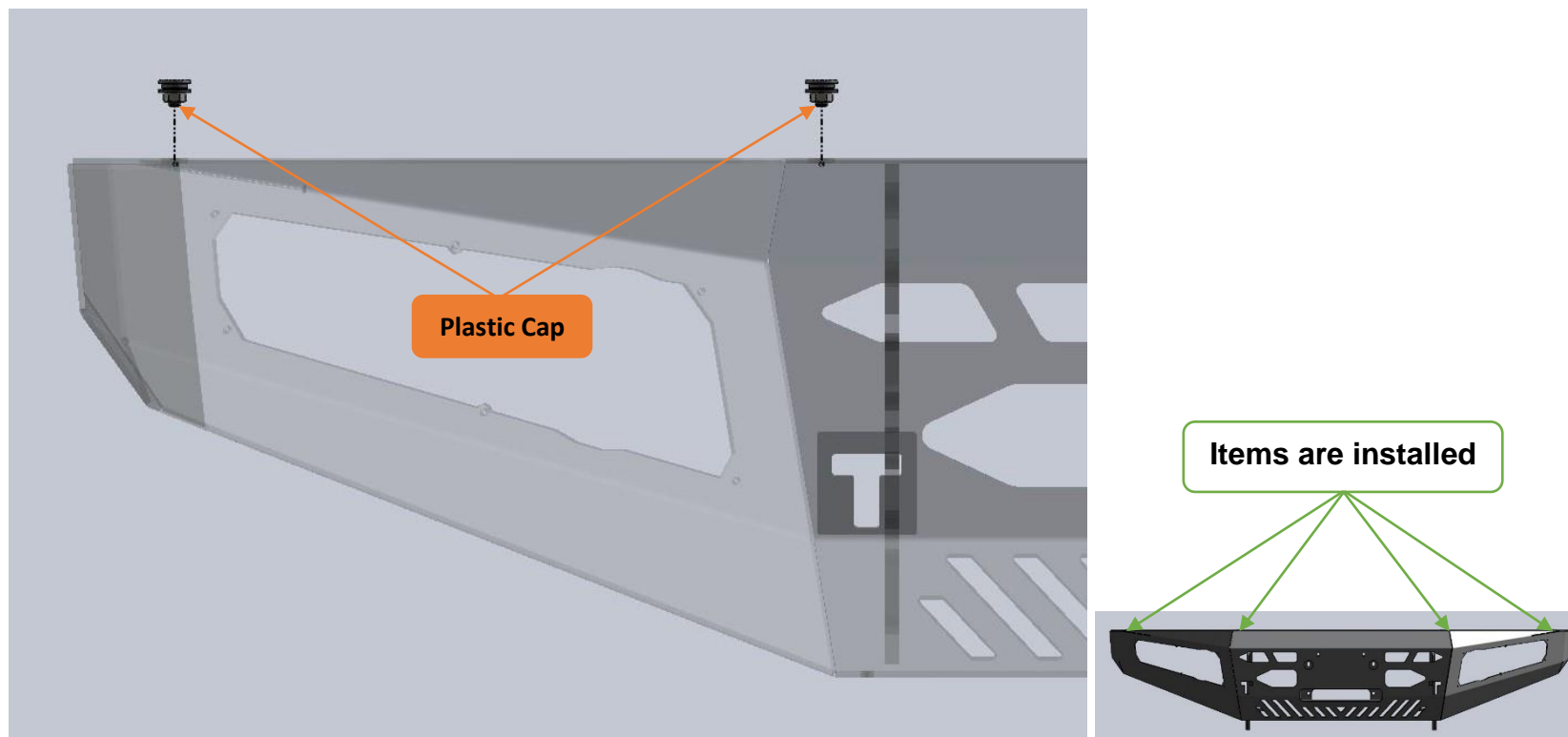

Plastic Cap x 04 pcs

Bolt Tightening Torque: 3(Nm)



WI-008-R0

**STEP 4.1:** Install Red Plate into Bottom Plate, bolted with 6 positions.

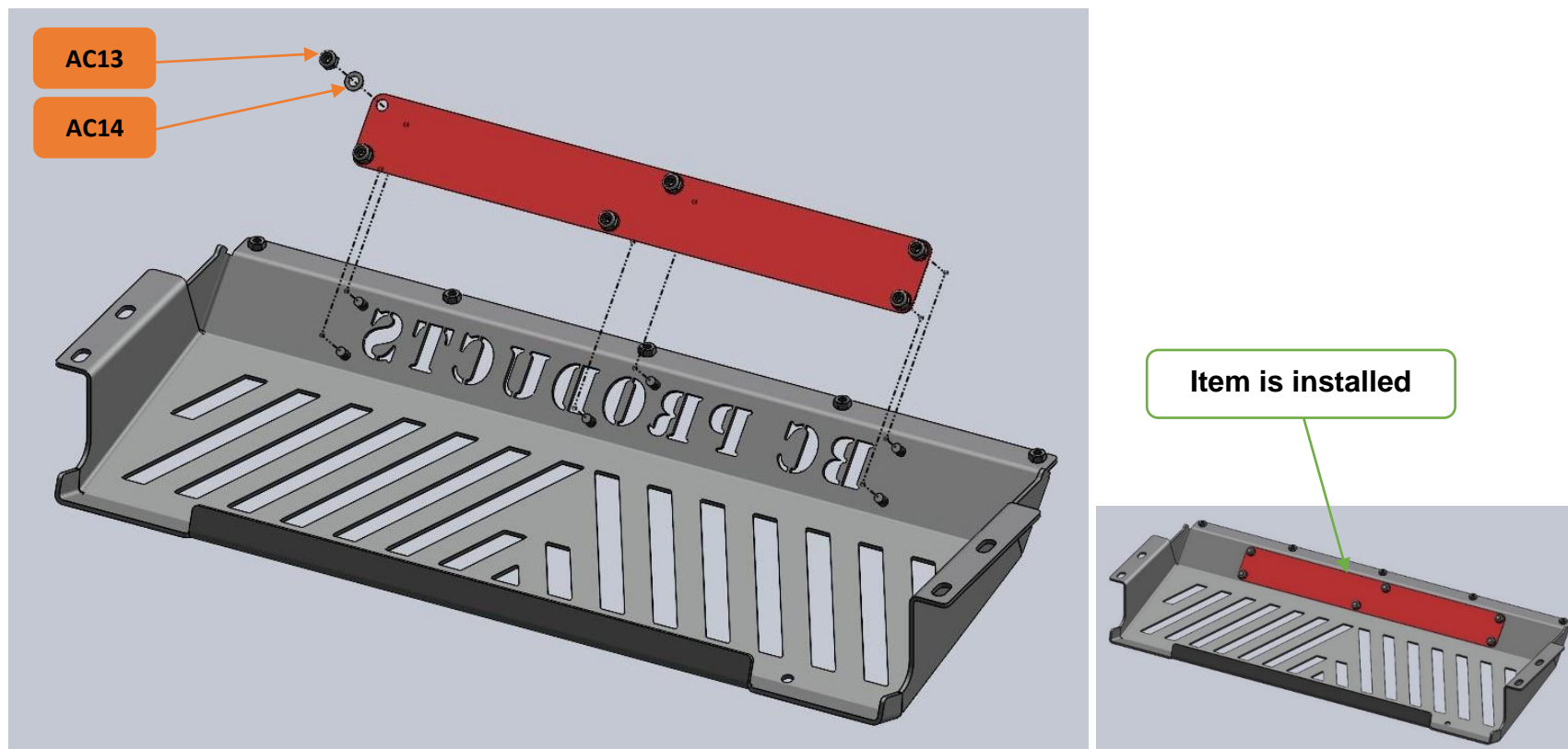

AC13 x 06 pcs : Nyloc Nut M8 x P1.25

AC14 x 06 pcs : Steel Flat Washer M8 x 8.4mmID x 17mmOD x 2.5mmT

**Bolt Tightening Torque: 24(Nm)**



WI-008-R0

**STEP 4.2:** Install Bottom Plate into the Car, bolted with 10 positions.

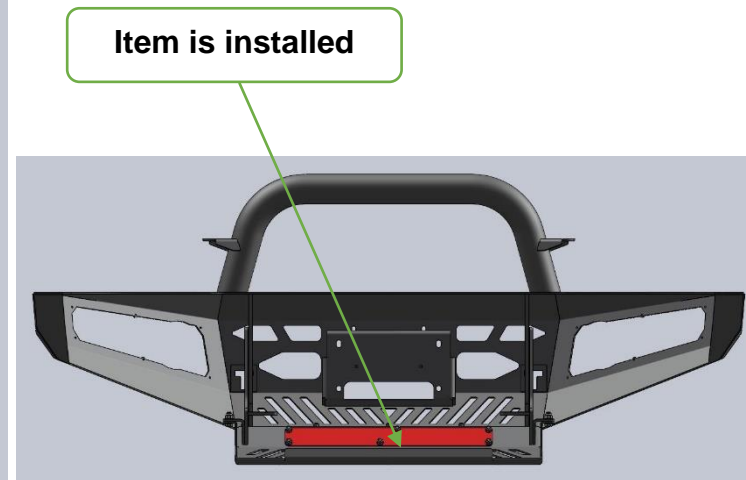
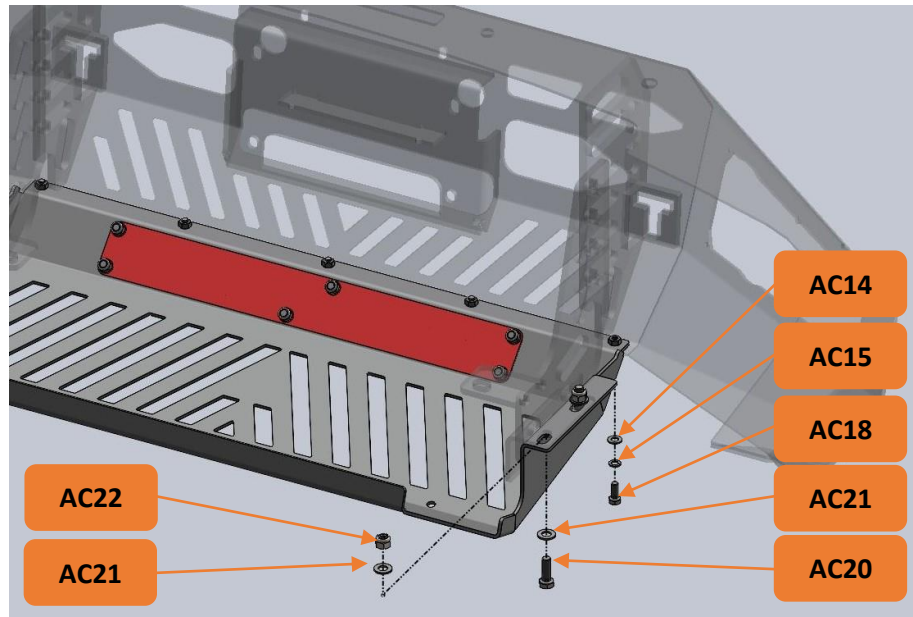

**AC14 x 06 pcs** : Steel Flat Washer M8 x 8.4mmID x 17mmOD x 2.5mmT

**AC15 x 06 pcs** : Steel Spring Washer M8

**AC18 x 06 pcs** : Hex Head Bolt M8 x 20mmL x P1.25

**Bolt Tightening Torque: 24(Nm)**

**AC20 x 04 pcs** : Steel Bolt M10 x 30 x P1.25

**AC21 x 08 pcs** : Steel Flat Washer M10 x 11mmID x 21mmOD x 2mmT

**AC22 x 04 pcs** : Steel Nyloc Nut M10 x P1.25

**Bolt Tightening Torque: 24(Nm)**

WI-008-R0

**STEP 5.1:** Install Frog Light into Light Panel LH & RH, bolted both side with 8 positions.

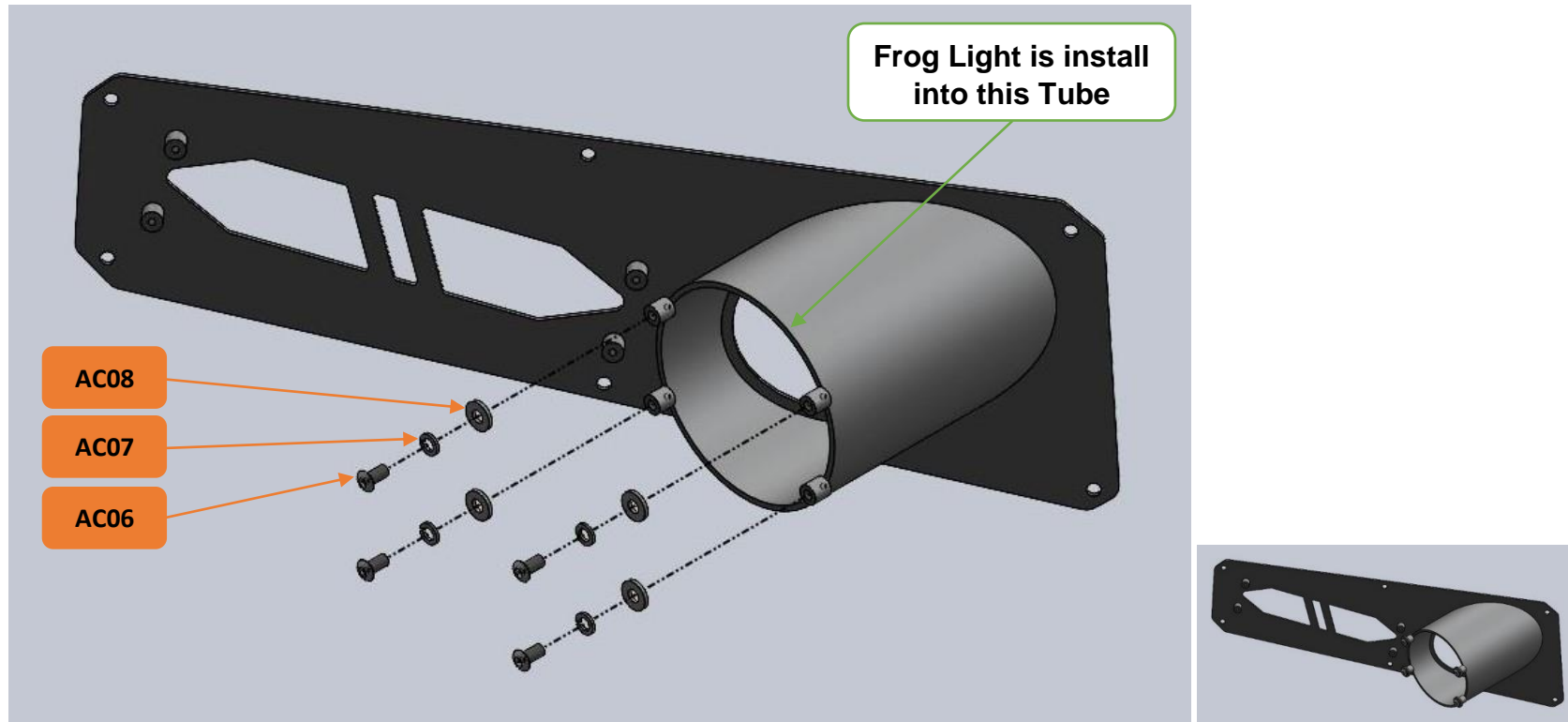

**AC31 x 01 pcs :** Frog Lights (Pair) with Accessories

**AC06 x 08 pcs :** M6 x 12mmL x P1 Steel Hex socket (allen Key) & Domed Head Bolt

**AC07 x 08 pcs :** Steel Spring Washer M6

**AC08 x 08 pcs :** Steel Flat Washer M6 x 6.6mmID x 15mmOD x 2mmT

**Bolt Tightening Torque: 10(Nm)**

WI-008-R0

**STEP 5.2:** Install Indicator Light into Light Panel LH & RH, bolted both side with 8 positions.

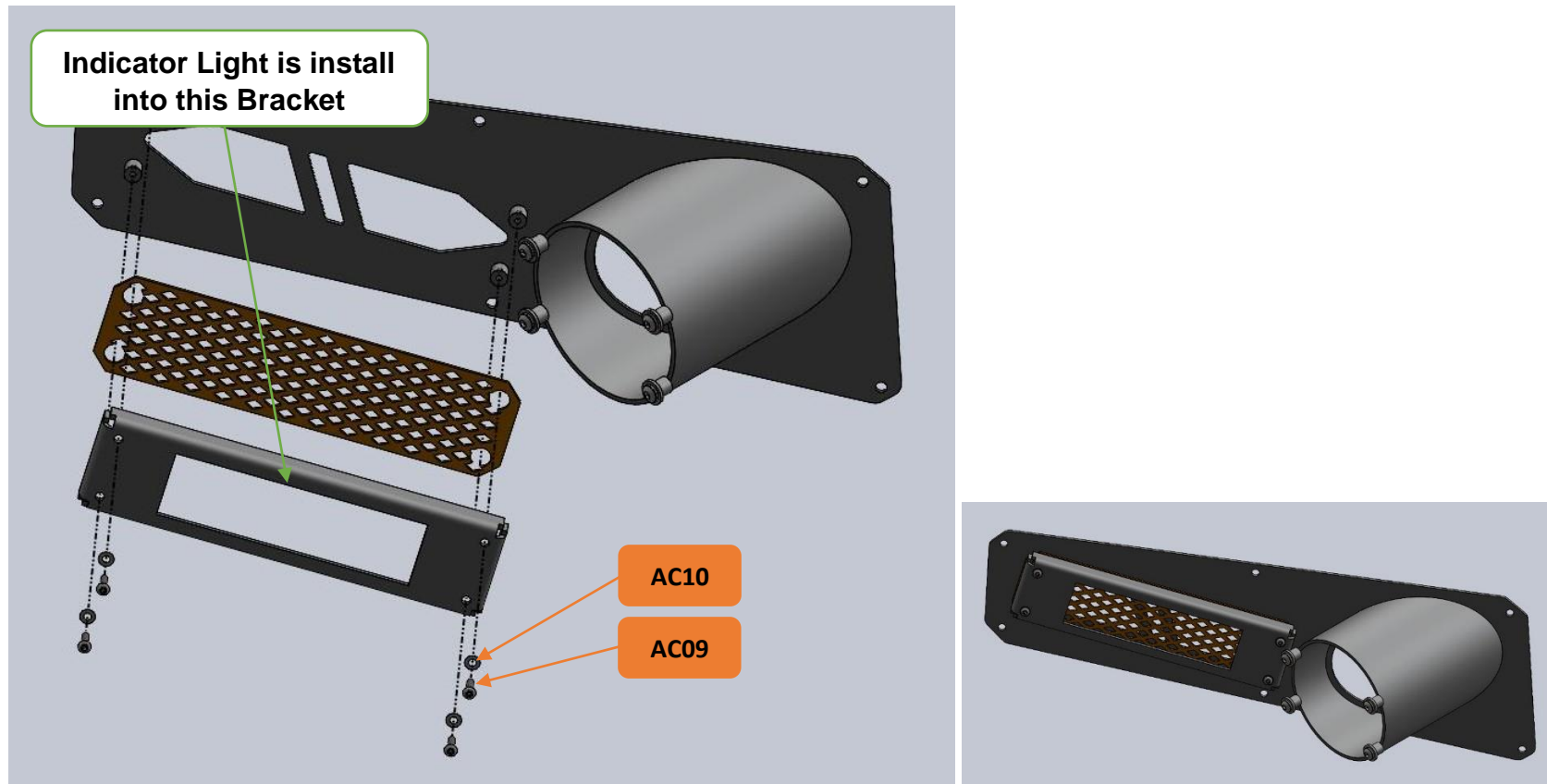

**AC32 x 01 pcs :** Indicator Lights (Pair)

**AC09 x 08 pcs :** M4 x 15mmL x P0.7 Hex socket (allen Key) & Domed Head Bolt

**AC10 x 08 pcs :** Steel Flat Washer M4 x 4.3mmID x 9mmOD x 0.8mmT

**Bolt Tightening Torque: 3(Nm)**

WI-008-R0

**STEP 5.3:** Install Light Panel LH & RH, bolted both sides with 12 positions.

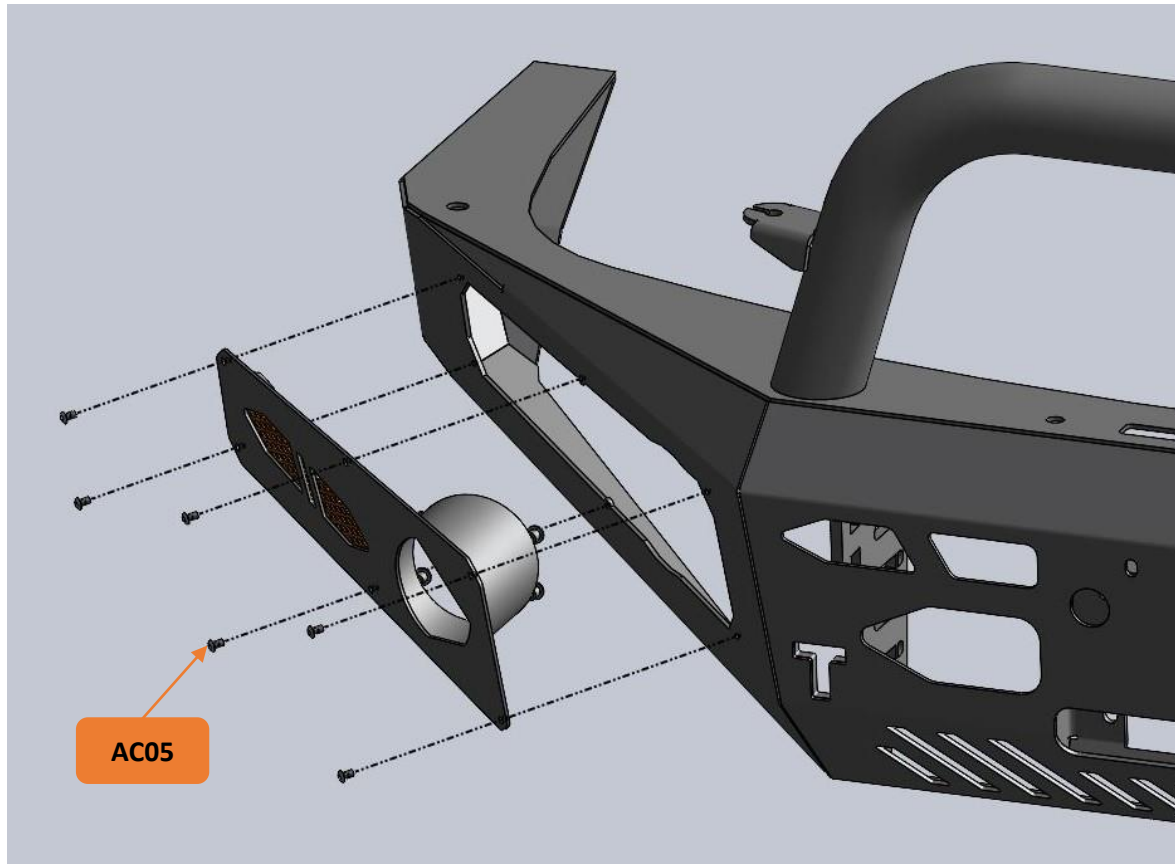

**AC05 x 12 pcs :** M6 x 10mmL x P1 Steel Hex socket (allen Key) & Domed Head Bolt  
**Bolt Tightening Torque: 10(Nm)**

WI-008-R0

**STEP 6.1: Install License Bracket into Bull Bar, bolted with 2 positions.**

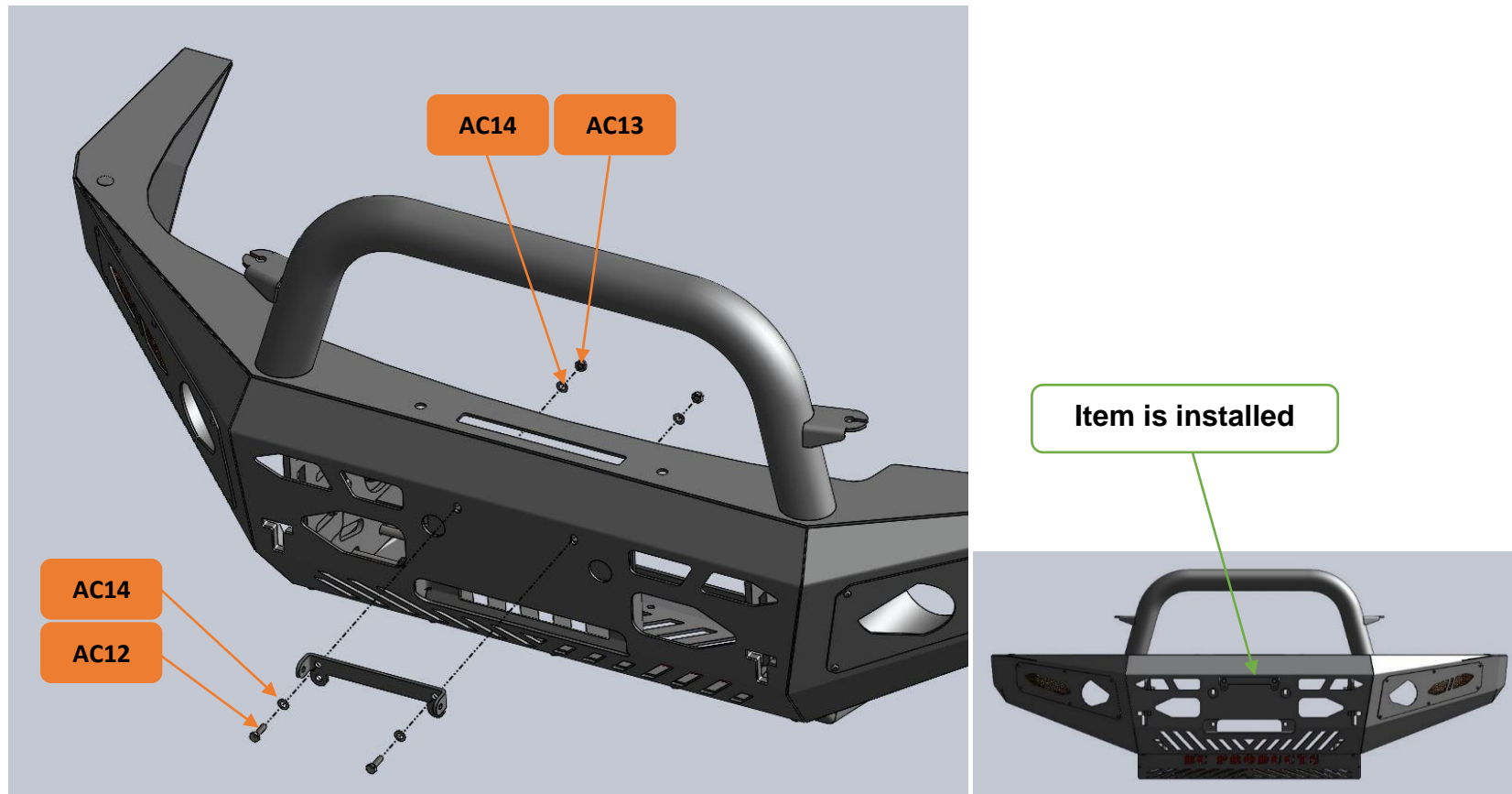

**AC12 x 02 pcs** : Hex Head Bolt M8 x 25mmL x P1.25

**AC13 x 02 pcs** : Nyloc Nut M8 x P1.25

**AC14 x 04 pcs** : Steel Flat Washer M8 x 8.4mmID x 17mmOD x 2.5mmT

**Bolt Tightening Torque: 24(Nm)**

WI-008-R0

**STEP 6.2: Install License Plate Bracket, bolted with 2 positions.**

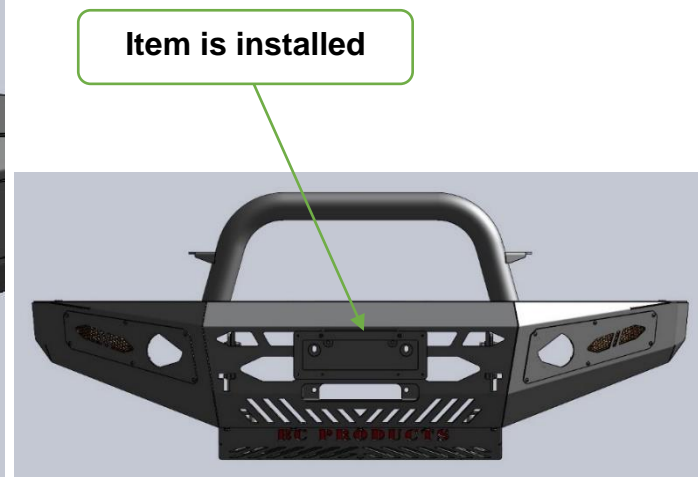
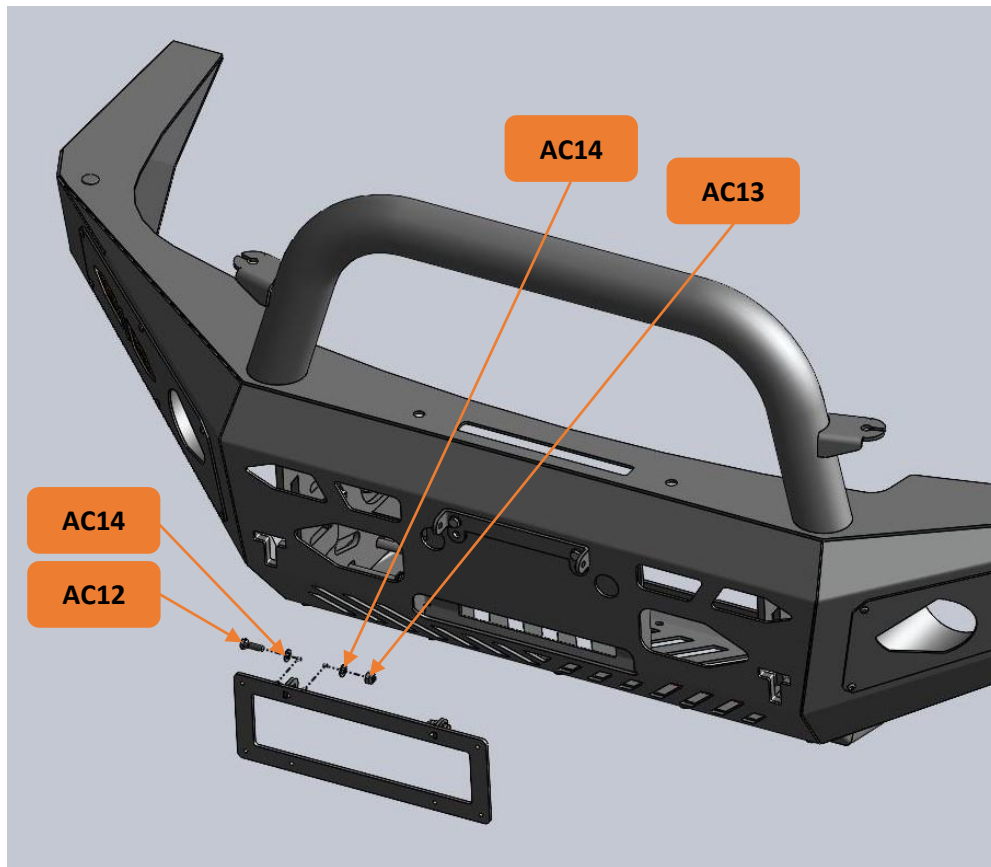

**AC12 x 02 pcs** : Hex Head Bolt M8 x 25mmL x P1.25

**AC13 x 02 pcs** : Nyloc Nut M8 x P1.25

**AC14 x 04 pcs** : Steel Flat Washer M8 x 8.4mmID x 17mmOD x 2.5mmT

**Bolt Tightening Torque: 24(Nm)**



WI-008-R0

**STEP 6.3:** Install License Plate into the Bracket, bolted with 4 positions.

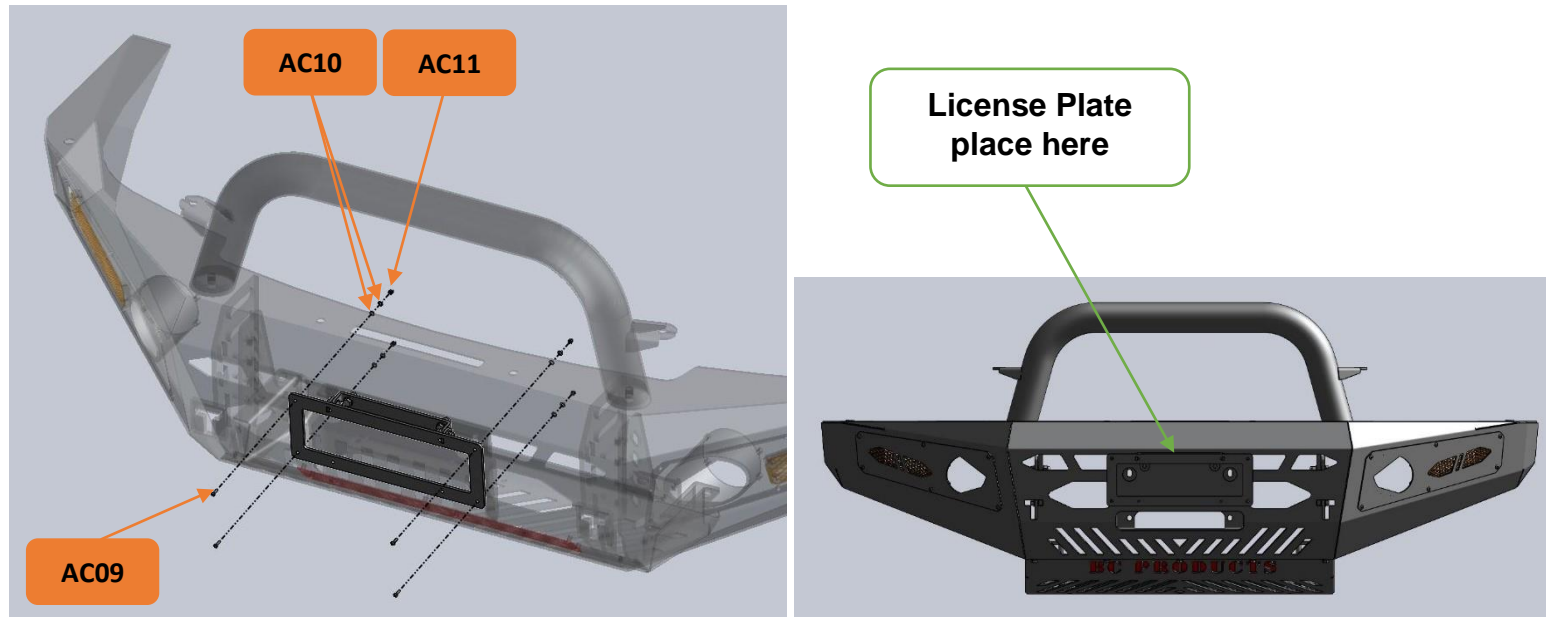

**AC09 x 04 pcs :** M4 x 15mmL x P0.7 Hex socket (allen Key) & Domed Head Bolt

**AC10 x 08 pcs :** Steel Flat Washer M4 x 4.3mmID x 9mmOD x 0.8mmT

**AC11 x 04 pcs :** Nyloc Nut M4 x P0.7

**Bolt Tightening Torque: 3(Nm)**

**Recommendation:**

Due to the variation of vehicle chassis some shimming may be required by using the extra washers supplied (**AC04**) to assist in lining up the bar where required.

----- END -----