

8

7

6

5

4

3

2

1

D

D

C

C

B

B

A

A

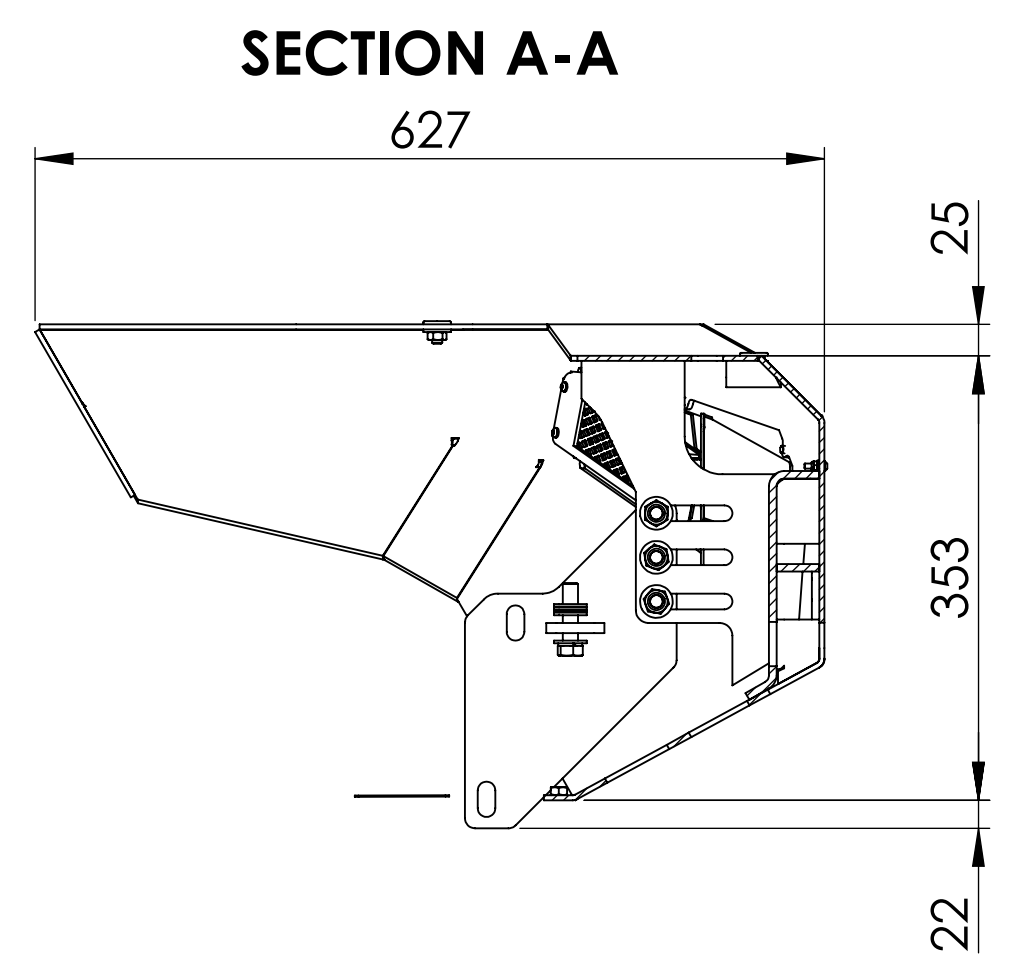
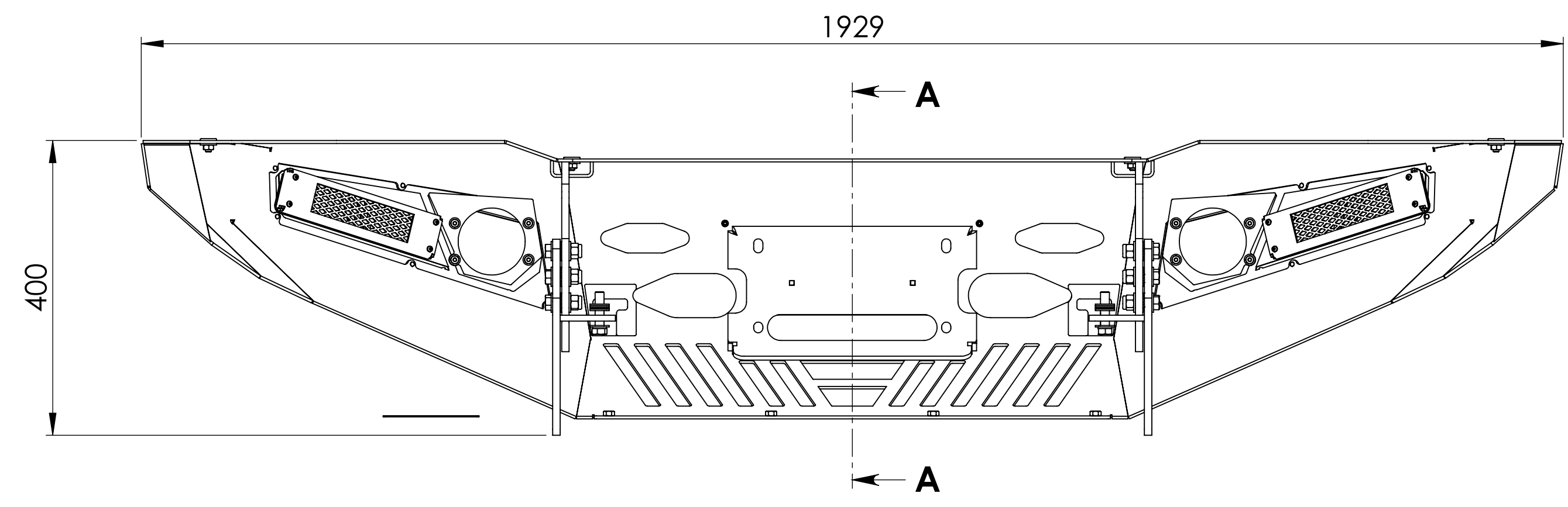
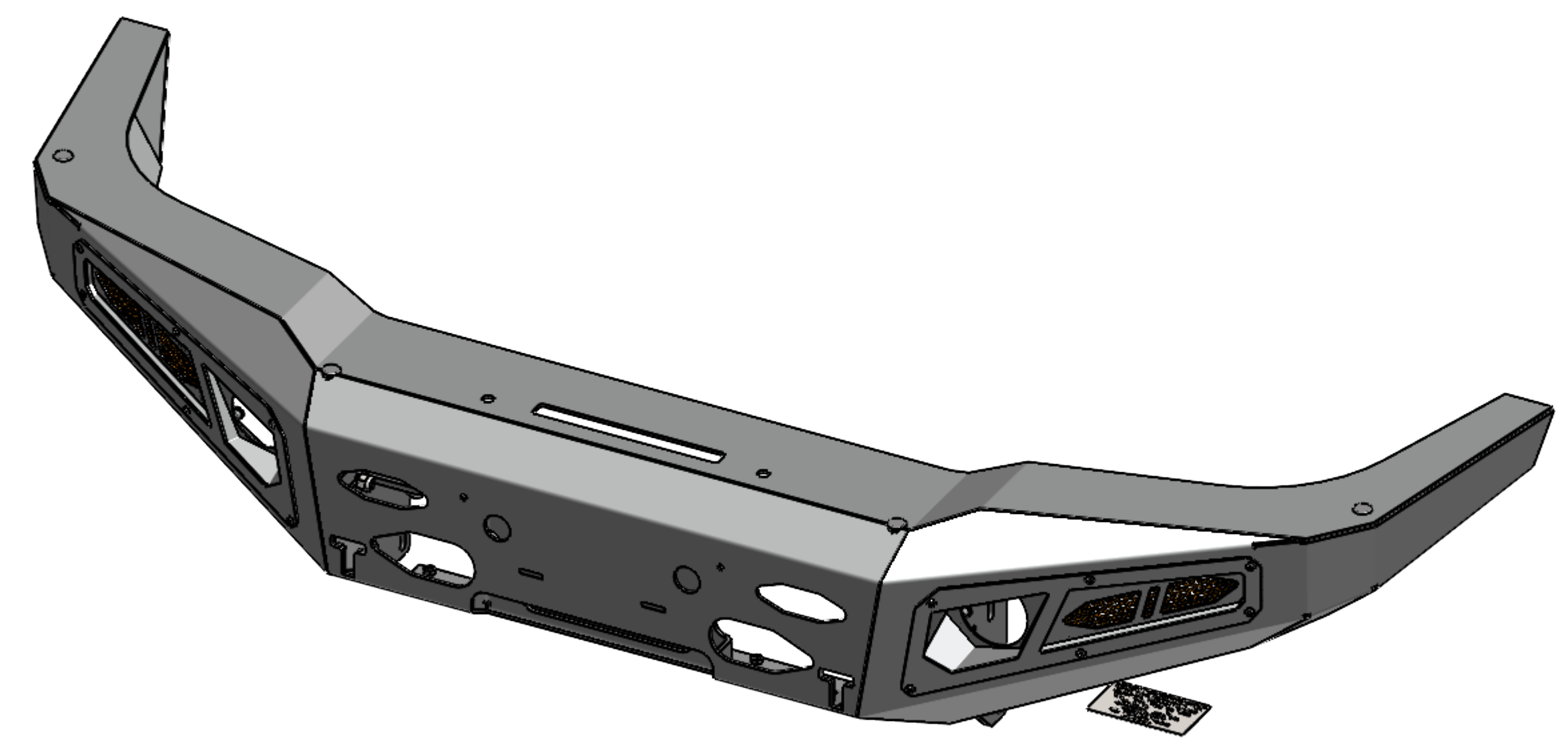
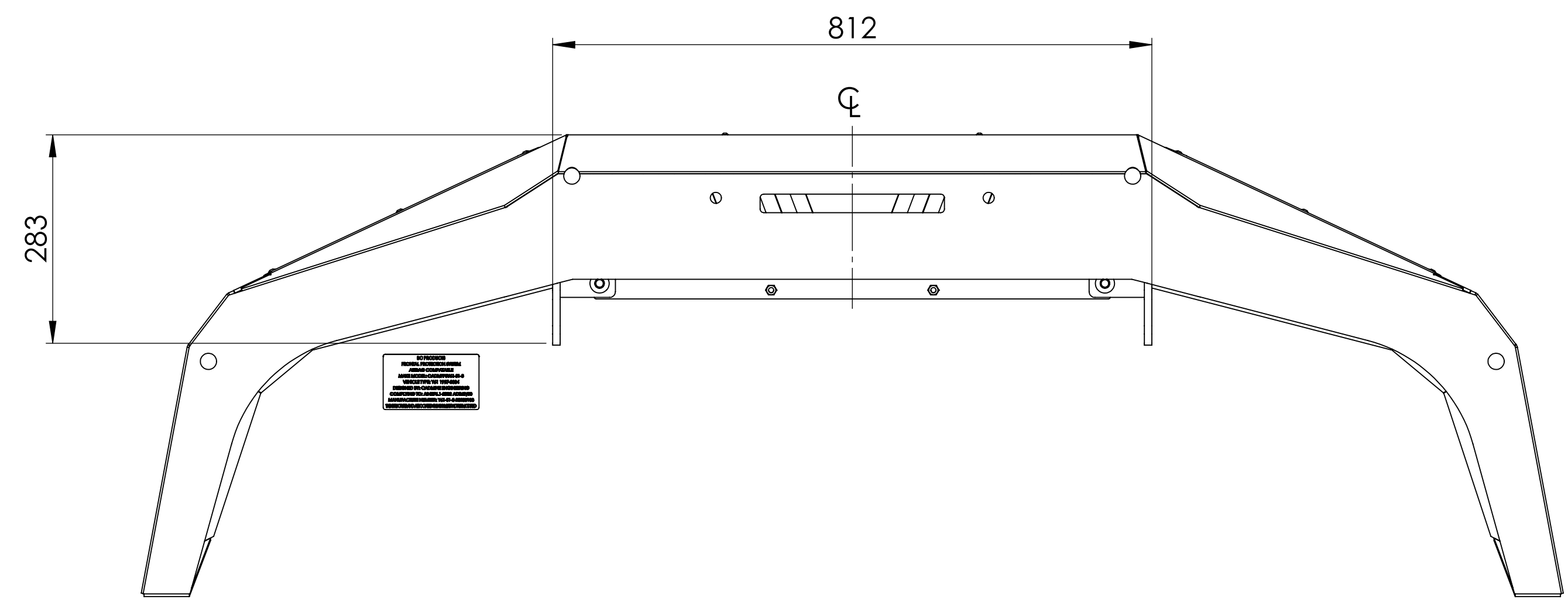

ENGINEERING VERIFICATION	
RATED WLL	_____
DES. STANDARD	TBA
CALCULATION No	TBA
APPROVED DATE	TBA
APPROVED REV	TBA
APPROVED BY	TBA
SIGNATURE	_____
TESTING REQUIRED IN ACCORDANCE WITH APPLICABLE DESIGN STANDARD	

This drawing and all the information thereon remains the property of CADmine and shall be returned on demand. It is issued on the condition that, except with written permission, it must not be reproduced, copied, or communicated to any party, nor to be used for any other purpose than that stated on the particular enquiry, order, or contract with which is was issued. Acceptance of this drawing signifies acceptance of the above conditions and copyright.

TOLERANCE ON DIMENSIONS UNLESS NOTED OTHERWISE	
MACHINING	
- One Decimal Place :	0.10
- Two Decimal Places :	0.05
- Angular :	0.5°
- Surface Finish :	N8/
FABRICATION	
- Up To 300	±1
- 301 To 1000	±1.5
- 1001 To 3000	±2
- 3001 To 5000	±2.5
- Over 5000	±3
- Angular	1°

DWG No.	TITLE	No.	DESCRIPTION	BY	DATE	CHK	DATE	APP	DATE
	REFERENCE DRAWING		DRAWING REVISIONS						

SIGNED APPROVED	
ENG	
DRN	
CHK	
APP	
ORIGINAL DWG SIZE	



DRAWN	
CHECKED	
Q.A.	
MFG	
APPROVED	
3RD ANGLE PROJECTION	

PROJECT: 1131 GU-PAT-3-PC Nissan GU Patrol Series 3 Bull Bar No Hoop - Powder Coated			
TITLE: Nissan GU Patrol Series 3 Bull Bar No Hoop - Powder Coated			
WEIGHT =/>:	SIZE	MR:	DWG. NO.
47.6 Kg	D	SEE BOM	1131 GU-PAT-3-PC
SCALE 1:4	FINISHED: TBA	REV	10
			SHEET 1 OF 1

8

7

6

5

4

3

2

1